



OPERATION AND MAINTENANCE MANUAL
FOR
RIKEN OXYGEN GAS DETECTOR HEAD
GD-F3A-1

Request for the Customers

- Read and understand this operating manual before using the detector head
- Use the detector head in accordance with the operating manual.
- Regardless of warranty period, we shall not make any indemnification for accidents and damage caused by using this product.
The indemnification shall be made only under the warranty policy of products or parts replacement.
- Because this is a safety unit, a regular maintenance for every six months and daily maintenance must be performed
- If any abnormality was found in the detector head, notify them to RIKEN KEIKI immediately.

RIKEN KEIKI Co., Ltd.

2-7-6 Azusawa, Itabashi-ku, Tokyo, 174-8744, Japan

Phone : +81-3-3966-1113

Fax : +81-3-3558-9110

E-mail : intdept@rikenkeiki.co.jp

Web site : <http://www.rikenkeiki.co.jp/english/>

[CAUTIONS ON OPERATION]

This is a fixed type gas detector (head) and alarm instrument to detect oxygen gas in air. The gas alarm instrument is a safety instrument, not an analyzer nor measuring instrument to make quantitative and qualitative analysis or measurement.

Please understand following points and use this detector head correctly.

1. The indication on this detector has some changes against fluctuation of atmospheric pressure. Especially, take care about alarm action at the time of depression caused by typhoon.
It may also fluctuate against the environmental (temperature, humidity, etc.) change around detector head.
2. Alarm level for gas alarm instrument shall be set within the performance of the instrument. Our standard alarm level is 18% by volume for the prevention of oxygen deficiency.
3. This is not control equipment, but a safety instrument.
Use the alarm contact from gas alarm instrument only for external alarm light or buzzer.
And the analog output signal shall be used only for external indicator or recorder.
We do not assume indemnification for any accident or damage caused by other control purpose than the above.
4. To maintain the performance of this gas detector, the regular maintenance service including the regular parts replacement and adjustment described in this manual shall be required. Also every 6 months regular maintenance and gas calibration are required since this is a safety instrument.

TABLE OF CONTENTS

| | |
|--|-----------|
| 1. PRODUCT OUTLINE | |
| 1- 1. Preface | 3 |
| 1- 2. Application for use | 3 |
| 1- 3. Identification of each signal word | 3 |
| 2. IMPORTANT INSTRUCTIONS FOR THE SAFETY | |
| 2- 1. Danger items..... | 4 |
| 2- 2. Warning items..... | 4 |
| 2- 3. Caution items..... | 4 |
| 2- 4. Cautions for the explosion proof (In case of intrinsically safe design)..... | 4 |
| 3. PRODUCT FUNCTION | |
| 3- 1. External drawing..... | 5 |
| 3- 2. Name of each part and functions..... | 6 |
| 3- 3. System composition | 6 |
| 4. HOWTO USE | |
| 4- 1. Before operation..... | 9 |
| 4- 2. Installation place | 9 |
| 4- 3. Maintenance space | 9 |
| 4- 4. Installation works | 9 |
| 4- 5. Caution at wiring construction | 10 |
| 4- 6. Applicable cable | 10 |
| 4- 7. Example of cable connection | 10 |
| 5. OPERATION METHOD | |
| 5- 1. Preparation before start up | 12 |
| 5- 2. Start up..... | 12 |
| 5- 3. Stopping the operation | 12 |
| 6. MAINTENANCE AND INSPECTION | |
| 6- 1. Inspection frequency and items | 13 |
| 6- 2. Calibration | |
| 6- 2- 1. Required kit and tools for calibration..... | 14 |
| 6- 2- 2. Performing a zero adjustment | 14 |
| 6- 2- 3. Performing a span adjustment..... | 14 |
| 6- 3. Replacing the sensor | |
| 6- 3- 1. Replacement frequency of the sensor..... | 15 |
| 6- 3- 2. Replacing the sensor | 15 |
| 6- 4. Storage or treatment when not in use for a long period..... | 16 |
| 6- 5. List of recommendable spare parts for regular replacement | 16 |
| 7. MEASURES AT ABNORMAL CASE | |
| 7- 1. Responding to trouble alarm | 17 |
| 7- 2. Before it is thought to be a trouble..... | 17 |
| 8. DEFINITION OF TERMS..... | 17 |

| | |
|-------------------------------------|-----------|
| 9. PRODUCT SPECIFICATIONS | |
| 9- 1. Standard specifications | 18 |
| 9- 2. Standard accessories | 18 |
| 9- 3. Optional accessories | 18 |
| 10. DETECTION PRINCIPLE..... | 19 |

1. PRODUCT OUTLINE

1 – 1 . Preface

Thank you for purchasing our fixed type Oxygen Detector Head GD-F3A-1. First of all, verify that the model number of this product is identical with specifications described in this manual. This manual is a guide to operation of the GD-F3A-1. All persons who use unit for the first time and who has ever used this unit are requested to read through the manual to understand the content before use.

1 – 2 . Application for use

This is a diffusion type oxygen detector head applying the galvanic cell type oxygen sensor and is used in combination with indicator / alarm unit to show oxygen content. Read the instruction manual for indicator / alarm unit as well as this manual.

This unit is designed as drip-proof construction for outdoor installation.

Also, it can be used as intrinsically safe system in combination with zener barrier (option) to be able to install in hazardous area.

1 – 3 . Identification of each signal word

This manual contains the following headings to ensure the safe and effective operation.



Indicates an imminently hazardous situation which, if not avoided, will result in death or serious injury or serious damage to the product.

This signal word is to be limited to the most extreme situation.



Indicates a potentially hazardous situation which, if not avoided, could result serious injury to the human body or object.



Indicates a potentially hazardous situation which, if not avoided, may result in minor or moderate injury or some damage to the human body or objects. It may also be used to alert against unsafe practices.



This means “ADVICE” regarding operation.

2. IMPORTANT INSTRUCTIONS FOR THE SAFETY

2- 1. Danger items



In case of non-explosion proof system, do not use this unit at the place where combustible gas may exist.

2- 2. Warning items



- Do not cut the wire for protective ground both inside and outside of instrument. Or, do not disconnect the connection of the ground terminals.
- Before starting the operation, check if any defect is not found on the protective grounding. If there is any defect on the protective functions such as protective grounding, do not start the operation.
- It is very dangerous if the instrument gives oxygen deficiency alarm. Take appropriate measures based on your judgment at that time.
- Perform gas calibration at proper interval.
- Do not change or remodel the circuit/structure of this unit.
- Do not disassemble the sensor since there is an electrolyte inside. If your finger touches the electrolyte, wash your finger way with water immediately.

2- 3. Caution items



- Do not use a walky-talky around the instrument. The indication might be affected by the electromagnetic wave generated by the walky-talky if it is used near the instrument. When the walky-talky is used, be away enough from the instrument not to affect.
- Do not control other equipment by using outputs of this detector. This is not a control equipment. It is prohibited to control other equipment by using outputs of this detector.

2- 4. Caution for explosion proof (In case of intrinsically safe design)



- Do not use this detector head expect for the measurement of oxygen content in a mixture of air and combustible gas or vapors, or a mixture of air and toxic gases.
- When clearing this unit, do not use dry cloth but use the wet cloth not to change the static electricity on plastic part.

3. PRODUCT FUNCTION

3 – 1 . External drawing

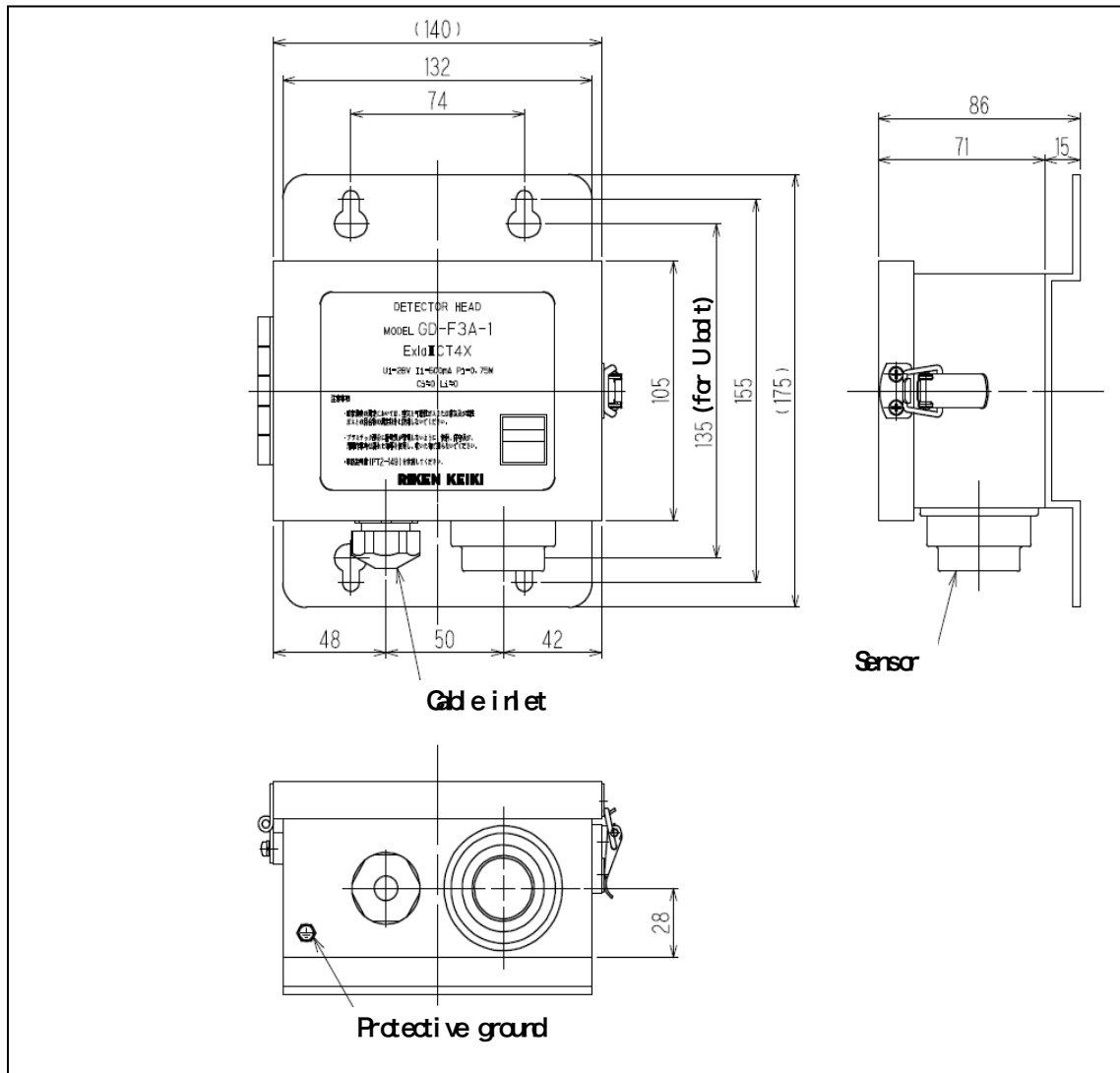

3 - 2. Name of each part and functions

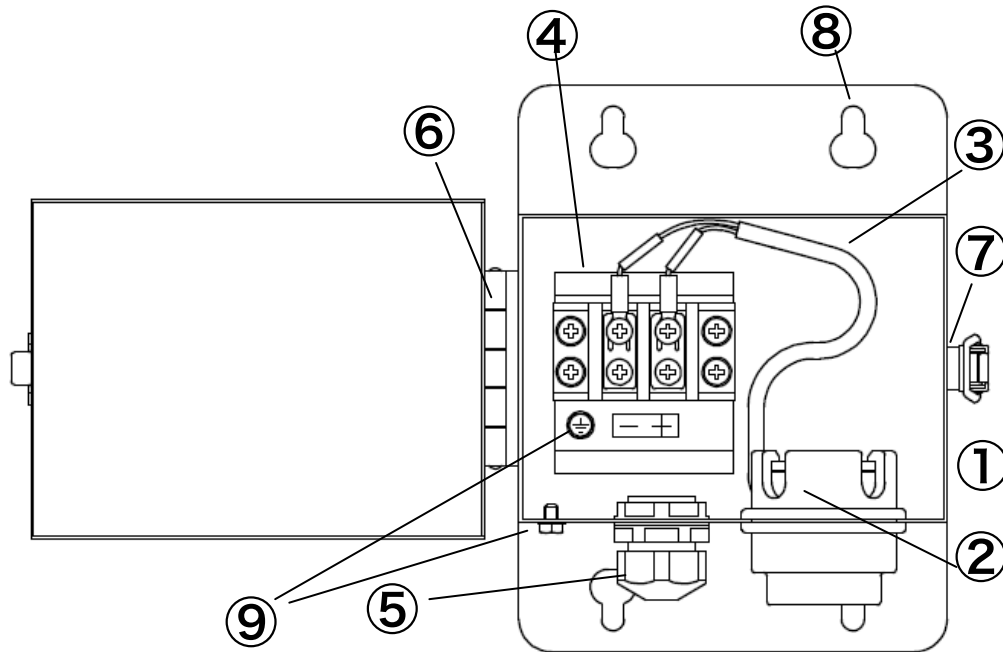

- | | |
|-------------------------|---|
| ① Oxygen sensor | : Galvanic type sensor to detect oxygen content. |
| ② Sensor holder | : This is a retainer to hold the oxygen sensor (equipped filter inside). |
| ③ Sensor lead | : Lead wires for oxygen signal outputs. |
| ④ Terminal strip | : Relay terminal for sensor lead and external cable. |
| ⑤ Cable gland | : Entrance to lead the cable ($\phi 8 \sim \phi 11\text{mm}$) from outside. |
| ⑥ Hinge | : Hinge for front door. |
| ⑦ Lock | : Lock for front door. |
| ⑧ Mounting hole | : Mounting hole to fix this unit on the wall surface. |
| ⑨ Protective earth bolt | : Bolt for protective grounding |

3 - 3. System composition

(1) Intrinsically safe system

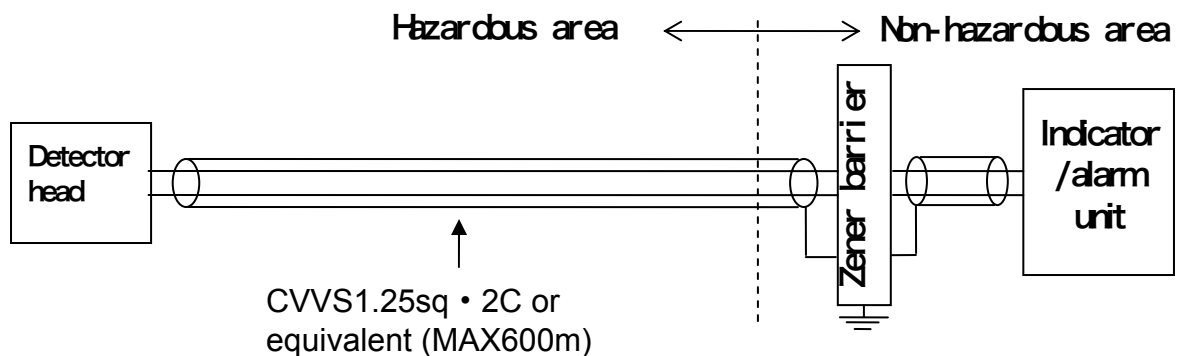

 **WARNING**

1. The oxygen detector shall be used as following composition.

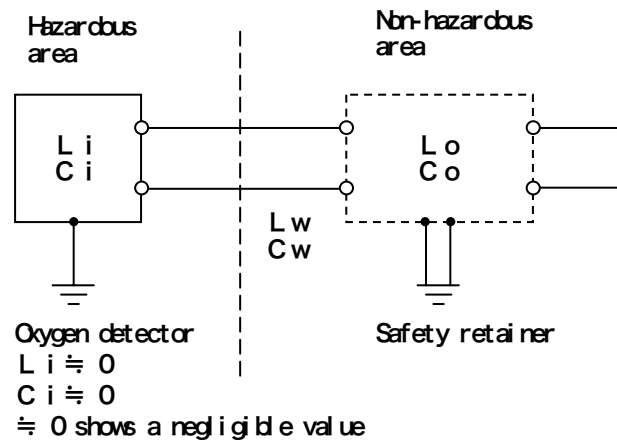

2. The safety retainer to be connected with oxygen detector shall have linear characteristics and be passed the type approval as it is. Also it shall satisfy the following conditions.

(1) Rating of safety retainer

Max voltage of intrinsic- safety circuit: Below 28V

Max current of intrinsic- safety circuit: Below 600 mA

Max power of intrinsic- safety circuit: Below 0.75W

(2) Performance division and group

Performance division: ia

Group: II C

(3) Relations between allowable inductance (L_o) and allowable capacitance (C_o) of intrinsic- safety circuit, and external wiring inductance (L_w) and capacitance (C_w) of intrinsic- safety circuit.

$$L_o \geq L_i + L_w$$

$$C_o \geq C_i + C_w$$

(4) When making wiring connection for intrinsic- safety circuit, take care not to induce an electric current and voltage which will spoil the performance of intrinsically safe by the electromagnetic induction or electrostatic induction to the intrinsic- safety circuit.

(2) Non-explosion proof system

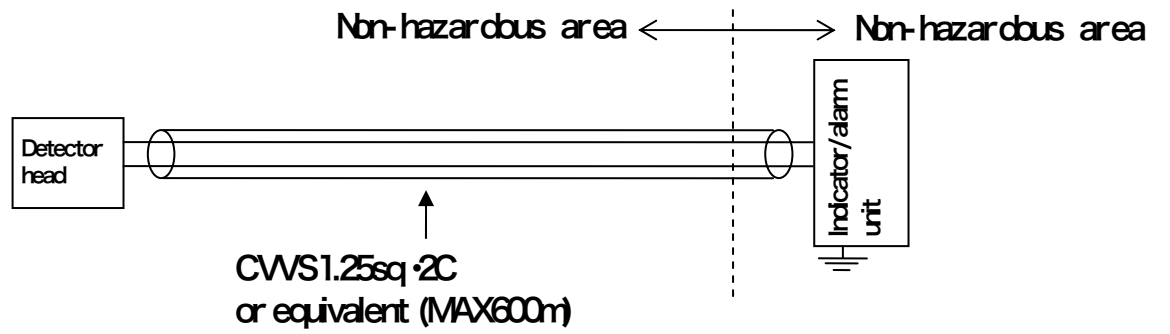

(3) Component inside detector head

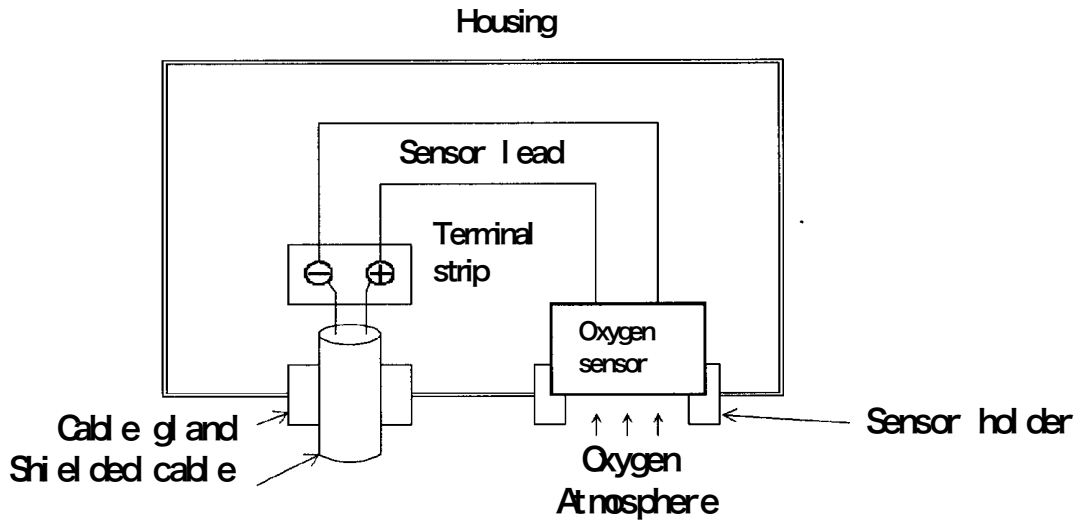

4 HOWTO USE

4- 1. Before operation

All persons who use this detector for the first time and who has even used the detector are requested to follow all the instructions for use carefully. If not, the instrument may be defective and correct gas detection may not be performed

4- 2. Installation place

This detector head is installed at the place of oxygen detection directly since this is a diffusion detector head

Note the following points.

⚠ WARNING

Do not install the detector head and cable at the following points.

- ✦ Place to get direct rays of the sun
- ✦ Places closed to high temperature and/or emission of electromagnetic wave.
- ✦ Place with vibration or shocks.
- ✦ Place where the mounting part is weak and it is easy to come out.
- ✦ Place where it is difficult to make maintenance and inspection.
- ✦ Place unable to secure grounding
- ✦ Places where the temperature is drastically changed
- ✦ Places exceeding operating temperature and humidity.

4- 3. Maintenance space

A certain maintenance space must be secured around the detector head, so that the maintenance staff can perform the safe and correct maintenance work. Pay due attention to secure this space during work plan and execution.

4- 4. Installation work

(1) Mounting to the wall surface

Mount the detector head to a flat surface (wall surface, etc) with either M6 bolts or M10 bolts through mounting holes. Refer to '3-1. External drawing' for mounting pitch.

(2) Mounting to the pole

The unit can be mounted to the pole (2B pipe) by using the optional U-bolts as show right figure.

(3) Installation to the outbors

For outdoor installation, optional drip-proof cover is required to keep reliable detection although this is a drip-proof design. Contact authorized distributors, dealers or representative appointed by Riken Keiki Co., Ltd

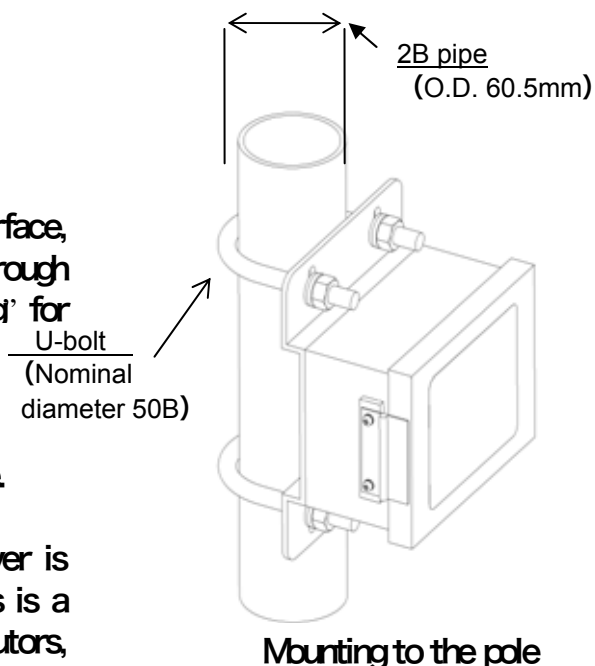

4- 5. Caution at wiring construction

CAUTION

- When make wiring construction, take care not to damage the internal electronics circuit.
- When handle the detector unit, put it at horizontal position. If put it vertically, it tends to fall and damage the detector.
- Power cable and signal cable shall not be laid down together with motive power cable such as motor, etc.
- When use twisted cable, take care not to contact a part of core cable with other core cable.

4- 6. Applicable cable

Signal transmission : CWS 1.25mm², 2C or equivalent
 Transmission distance : Within 600m at total
 Cable O.D. : φ8-φ11mm

4- 7. Example of cable connection

(1) In case of non-explosion proof system

- ① Lead the applicable cable through cable inlet and connect to the terminal strip
- ② Connect the shielding wire to chassis ground

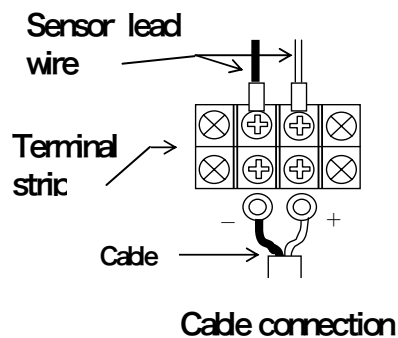

(2) In case of intrinsically safe system

You can build the intrinsically safe system by adding optional zener barrier between detector head and indicator/alarm unit.

- ① Lead the applicable cable through cable inlet and connect to the terminal strip
- ② Connect the optional zener barrier between this unit and indicator/alarm unit at non-hazardous area. (See below fig)
- ③ Connect the shielding wire to chassis ground

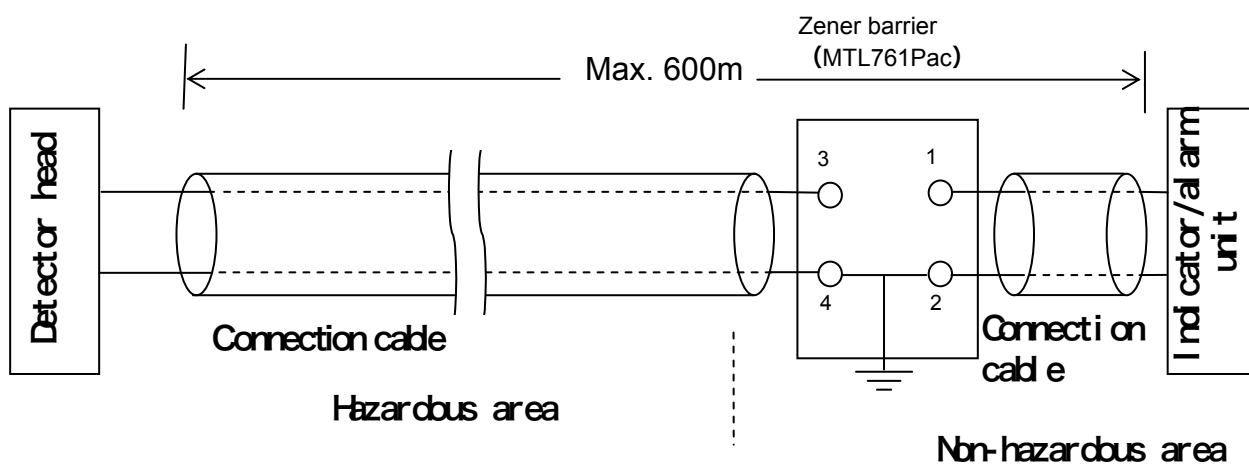

Example of intrinsically safe system

 **WARNING**

- Ground the zener barrier separately corresponding to the A-class grounding with ground resistance of 10Ω or less.
- Use the specified cable.
- For system installation, operation and maintenance, take care not to damage the intrinsically safe design.
- The power of the indicator/alarm unit shall be turned on after completion of all wirings. If each wiring is carried out in the power on condition, short-circuit between terminals or an electrical shock may be occurred

 **CAUTION**

- Do not alter, nor remodel the parts, etc.
- Use the circuit breaker as for the power of indicator/alarm unit. Also it shall be mounted nearby indicator/alarm unit and be specified that it is for power interruption of indicator/alarm unit.

*** NOTE**

When wiring read the operating instructions for the connected indicator/alarm unit.

5. OPERATION METHOD

5- 1. Preparation before start up

Before making power on, take care of the following. If do not keep this, there is the danger of electrical shock and damage of instrument.

WARNING

- Make grounding
- Check that the wiring with outer unit is made correctly.
- Check that the supply voltage is within the rating

5- 2. Start up

- ① This detector head does not equip a power switch. Analog outputs of oxygen sensor are transmitted to the indicator/alarm unit directly through the connected cable without signal conversion.
As far as the cable has been connected correctly, this system starts operation by putting on the power switch in indicator/alarm unit.
- ② Be sure to perform gas calibration at the time of new installation.
Correct reading may not be obtained before gas calibration.

CAUTION

•At the new installation, adjust the reading in indicator/alarm unit according to “6-2 Calibration”. Adjustment is done by indicator/alarm unit since the detector head has no functions for adjustment. Refer to operating instructions for the connected indicator/alarm unit.

5- 3. Stopping the operation

This system stops operation by putting off the power in indicator/alarm unit, since this unit has no power switch.

6. MAINTENANCE AND INSPECTION

Gas detection and alarm instrument is kept in continuous operation over a long time and must perform a vital role as a safety device. For this purpose, periodical inspection must be made. The High-pressure Gas Safety Act in Japan sets forth the obligation of periodical inspection of the gas detection and alarm instrument.

- Maintenance Contract -

Be sure to perform the regular maintenance inspection since this is an instrument for security and safety. If this detector head founds defective, contact our nearest agent or Riken Keiki soon.

6- 1. Inspection frequency and items

The inspection includes a daily inspection which a person in charge of control and operation of the gas detection instrument performs inspection before work once a day, and a monthly inspection carried out once a month, and periodical inspections conducted by the service personnel designated by manufacturer. The inspection items are confirmation of lights, concentration indication and alarm function on the indicator/alarm unit side. It is also necessary to carry out gas calibration at least every 6 months. The law in Japan sets forth that the unit must issue an alarm during the circuit inspection related to alarm while providing normal operation, at least, once a month.

To maintain the safety operation of the gas detection instrument, it is recommended to keep the maintenance contract with our authorized distributor for regular maintenance, adjustment and overhaul etc including the gas sensitivity adjustment (gas calibration).

For the detail of maintenance contract, contact our nearest agent or Riken Keiki.



WARNING

•This is a safety instrument and the inspection every 6 months or more is mandatory to ensure the safety. If the unit is used by continuously without inspection, the sensor sensitivity may change, resulting in failure of correct detection.

* NOTE

•Be sure to inform sections concerned beforehand when performing alarm test or gas calibration. For the equipment connected with output signal from indicator/alarm unit, perform them after disconnecting the output signal.

•Special trained engineer for gas detection instrument can perform maintenance work and inspection accurately and efficiently. Then, it is recommended to contact our authorized agent for maintenance and inspection.

6— 2 Calibration

Perform gas calibration at new installation, 6 months inspection and sensor replacement.

6— 2— 1. Required kit and tools for calibration

Prepare following jigs and tools to perform zero and span adjustments.

- Calibration adapter
- Calibration gas (standard gas for zero and span)
- Gas sampling bag for calibration gas
- Suction pump to lead calibration gas
- Flowmeter with flow control valve (enable to control 1.0L/min).

6— 2— 2. Performing a zero adjustment

- ① Pack the zero gas (Nitrogen more than 99.9 vol %) into gas sampling bag
- ② Connect calibration adapter, flowmeter (with flow control valve) and suction pump to the detector head. Turn on the pump and adjust the reading of flowmeter to 1.0 ± 0.3 L/min.
- ③ Connect gas sampling bag for calibration to the IN side of the pump.
- ④ After reading by indicator/alarm unit gets stable, adjust the reading to zero with respective potentiometer of indicator/alarm unit.
- ⑤ Stop the supply of zero gas, disconnect calibration adapter and confirm that the oxygen reading returns to 20.9 vol %

6— 2— 3. Performing a span adjustment

- ① Pack the span gas (fresh air for oxygen deficiency alarm instrument and their concentration is around preset alarm level for other purpose) into gas sampling bag. For simple calibration, you may be possible to use an ambient air as span gas containing 20.9 vol % O₂ providing that the ambient pressure is 1 atm (1000 ± 50 hpa) and contamination in air is negligible against span gas concentration.
- ② Connect calibration adapter, flowmeter (with flow control valve) and suction pump to the detector head. Turn on the pump and adjust the reading of flowmeter to 1.0 ± 0.3 L/min.
- ③ Connect gas sampling bag for calibration to the IN side of the pump.
- ④ After reading by indicator/alarm unit gets stable, adjust the reading to the span gas concentration with respective potentiometer of indicator/alarm unit.
- ⑤ Stop the supply of span gas, disconnect calibration adapter and confirm that the oxygen reading is 20.9 vol % (completion of span calibration).

6-3 Replacing the sensor

6-3-1. Replacement frequency of the sensor

To maintain the reliability of the measurement, it is recommendable to replace the sensor periodically. Our oxygen sensor has an enough life span. However, the actual life is depending on the operating conditions. **Then, replace the sensor once a year as the tentative deadline for the replacement cycle.**

6-3-2 Replacing the sensor

- ① Verify that the indicator/alarm unit is off. If the sensor is disconnected, the indicator/alarm unit issues an alarm
- ② Turn a lock of detector head and open the front door.
- ③ Loosen two screws at the top of terminal strip and disconnected two lead (black and white) wires.
- ④ Push the sensor upward from the bottom of sensor and pull out it from the holder.
- ⑤ Insert new sensor into the holder and push the sensor until it comes to the end
- ⑥ Connect black and white sensor lead wires to the terminal strip. Connect white wire to positive (+) terminal and black wire to negative (-) terminal respectively.
- ⑦ Close the front door of the detector head and fasten a lock.

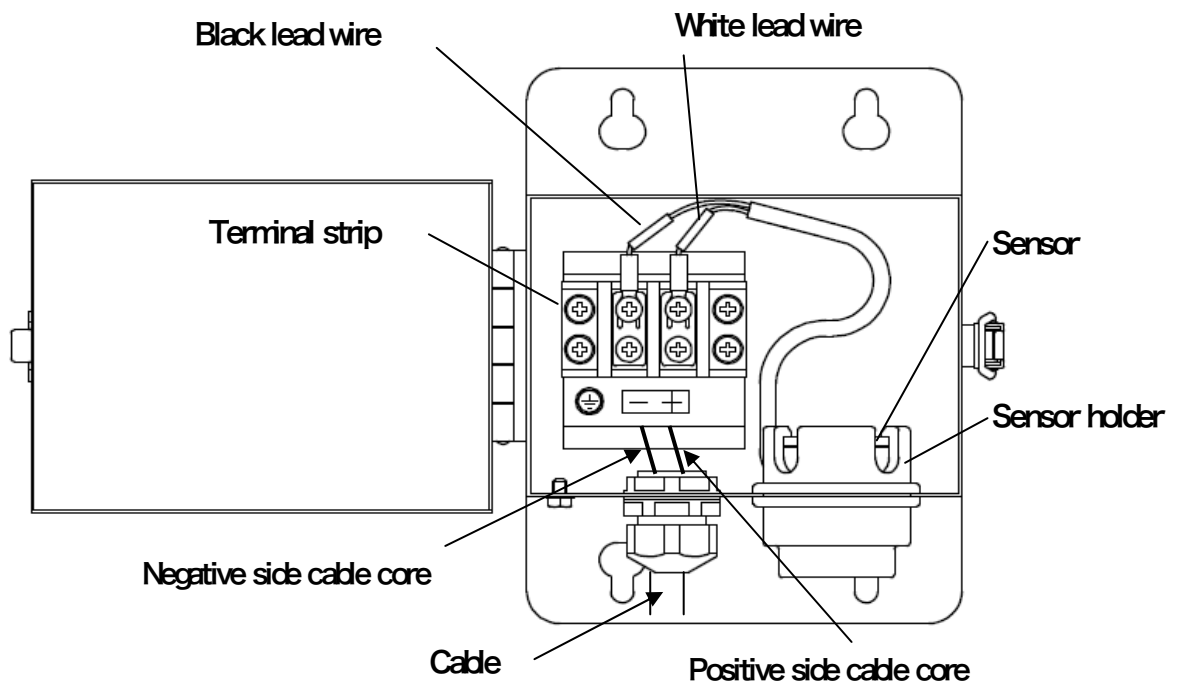

CAUTION

- Be sure to carry out gas calibration after sensor replacement. If not, correct gas detection may not be performed

6- 4. Storage or treatment when not in use for a long period

(1) Sensor

Oxygen sensor is a kind of cell and will continue to consume its life even though it is not used. When detector head is not used for a long period, take out the sensor from detector head and store it at following environment to lower the consumption of sensor.

Environment of temperature (5~10°C)

Environment of low oxygen content

(Put a sensor into the container and seal off the container.)

(2) Detector head

Store this detector head under the following environmental condition.

•Temperature : 0°C~40°C

•Humidity : 30%RH~85%RH

•Environmental condition : Environment where gas, solvent, vapor and so on are not existing



CAUTION

•Before re-start of operation, be sure to perform gas calibration.

•Contact our authorized agent or Riken Keiki for re-adjustment including gas calibration, replacement of parts, etc.

6- 5. List of recommendable spare parts for regular replacement

| No. | Name of parts | Inspection frequency | Replacement interval | Q'ty/unit |
|-----|---------------|-----------------------|-----------------------|-----------|
| 1 | Sensor holder | At sensor replacement | At sensor replacement | 1 |

* NOTE

The replacement interval will change depending on operating condition and it does not mean the guarantee period

Replacement interval changes according to the result of regular inspection.

7. MEASURES AT ABNORMAL CASE

7- 1. Responding to trouble alarm

If this detector founds defective, contact our authorized agent or Riken Keiki.

7- 2. Before it is thought to be a trouble

It may be caused by cable disconnection, short circuit, etc.

•Check the wirings around the related instruments as well as this detector head

It may be caused by improper operation.

•Re- check the detection system and contact our authorized agent or Riken Keiki.

8. DEFINITION OF TERMS

Galvanic cell

Galvanic cell type oxygen sensor that produces a current proportional to the oxygen content permeated through the membrane. Refer to “10. DETECTION PRINCIPLE” for details.

Zener barrier

Safety retainer for explosion protection by limiting the energy of electric current within a non-ignition level.

CWS

This is a kind of connecting cable between indicator/alarm unit and oxygen detector head

CWS means a “Polyethylene insulated and vinyl sheathed control cable with shield”.

Calibration

By using standard (calibration) gas, adjust gas reading in indicator/alarm unit to match the calibration gas concentration.

9. PRODUCT SPECIFICATIONS

9— 1. Standard specifications

| | |
|--------------------------|--|
| Model | : GD-F3A-1 |
| Detection principle | : Galvanic cell method |
| Target gas | : Oxygen in air |
| Sampling method | : Diffusion sampling |
| Signal transmission | : Sensor output direct transmission |
| Transmission distance | : Max 600m with CVVS 1.25sq 2C cable (between indicator/alarm unit and detector head) |
| Applicable zener barrier | : MTL761Pac |
| Cable entry | : Cable gland (Applicable cable O.D. : $\phi 8 \sim \phi 11$ mm) |
| Operating temperature | : -10~40°C |
| Operating humidity | : Below 90%RH (Non-condensing) |
| Structure | : Wall mounting/2B(50A) pole mounting |
| Kind of explosion proof | : Intrinsically safe (when zener barrier is used) |
| Explosion proof class | : Exia II CT4X (when zener barrier is used) |
| Outer dimensions | : Approx 175(H) × 140(W) × 86(D) mm |
| Weight | : Approx 1.4kg |
| Painting color | : Munsel No.25Y9/2 half tone |

9— 2. Standard accessories

- Operating instruction book

9— 3. Optional accessories

- U-bolt (for nominal diameter 2B)
- Calibration adapter
- Zener barrier (MTL761Pac)

1.0. DETECTION PRINCIPLE

The GD-F3A-1 employs a galvanic cell as oxygen detection sensor that consists of noble metal and base metal electrodes in an electrolyte.

A membrane covers the cell and allows gas in the sampled gas to diffuse into the electrolyte at a rate proportional to the partial pressure of oxygen. The oxygen reacts in the cell and produces a current proportional to the oxygen content. The current develops a voltage across a temperature compensation thermistor/resistor network. The voltage is measured by the indicator/alarm unit's circuitry, converted to an oxygen gas concentration.

