

Includes 25 Programmed Target Gases

Portable combustible gas detector

Model GP-1000

(Manufactured in Japan)

Target gas Select function

Methane, Iso-Butane, Hydrogen, Toluene, Xylene, Alcohol etc.
25 different target gases can be selected for direct readout



Target gas is selectable

Direct reading is selectable from a list of 25 gases. Calibration to only 1 gas (CH₄) is needed.

Pump booster function

Pump speed selectable from 0.3ml/min to 0.6ml/min. Gas can be sampled faster or from longer distance with higher pump rate.

Intrinsically safe

Safety rating ExiaIICT4 allows users to detect a gas at Zone 0 hazardous area where explosion hazards always exists.

Ingress protection rating IP67

Water proof, Dust proof construction for outdoor use meets IP67 rating.

Filters (optional) can be used with standard gas sampling probe

H₂S removal filter, silicone removal filter can be installed in standard gas sampling probe. Hydrogen sulfide or silicone that would damage sensor in GP-1000 can be removed by these filters.

Specification

Model	GP-1000
Gas detected	Combustible gas (CH ₄ , HC etc. Refer to the gas list)
Sensor principle	Catalytic combustion
Detection range	0 ~ 100%LEL
Alarm types	Gas alarm: Latching, 1 st and 2 nd alarm Trouble alarm: Low flow, sensor disconnection, low battery voltage, Circuit abnormality, detection range abnormality
Alarm methods	Gas alarm: Intermittent buzzer, flashing lights, gas concentration reading blinks Trouble alarm: Continuous buzzer, flashing lights, trouble condition is displayed
Preset alarms	1st: 10%LEL, 2nd: 50%LEL
Indication accuracy	Full scale +/- 5% (at same condition)
Response time	Within 30 seconds (T90)
Sampling method	Sample-draw, Flow rate > 0.3L/min (Approx. 0.6L/min for pump boosting mode)
Indication precision	Digital LCD with 7 segments + Bar meter (50 segment) + Status information Digital numeral 7 segments indication: 0 - 100%LEL Digital bar meter indication: Auto range (0 ~ 10%LEL / 0 ~ 100%LEL) 0~10 %LEL (L range) 0~100 %LEL (H range)
Power source	AA alkaline battery, 4pcs
Continuous operation	More than 20 hours (new battery, no alarm and no indication, at 25°C)
Operating temp. & humidity	Operating temperature -20 ~ 50°C [-4 ~ 122°F] Operating humidity 0 ~ 95%RH (Non-condensing) Storage temperature -25 ~ 60°C [-13 ~ 140°F] Storage humidity 0 ~ 95%RH (Non-condensing)
Dimension	80.1 (W) × 124 (H) × 36 (D) mm (3.15 (W) × 4.88 (H) × 1.42 (D) inches)
Weight	Approx. 260g (9.2 oz.) (exclude alkaline battery)
Water dust proof	IP 67
Safety design	Intrinsically safety ExiallCT4
Approvals	Ex-proof: IECEx, ATEX Other: CE marking
Function	LCD backlight, data log, log data indication, peak indication, pump boosting, gas select

Standard accessory



Hand strap



Sampling probe
(with water trap function)

Optional accessory



Carrying case



Protection film



Cartridge filter
• Silicone removal
• H₂S removal



Data logger
management program

Target gases

Sensitivity curve for 25 gases is originally loaded in GP-1000.
Target gas can be switched by button operation.

No.	Gas list	Name indicated on LCD	Lower explosion limit LEL
1	Methane	CH ₄	5.0vol%
2	Isobutane	i-C ₄ H ₁₀	1.8vol%
3	Hydrogen	H ₂	4.0vol%
4	Methanol	CH ₃ OH	5.5vol%
5	Acetylene	C ₂ H ₂	1.5vol%
6	Ethylene	C ₂ H ₄	2.7vol%
7	Ethane	C ₂ H ₆	3.0vol%
8	Ethanol	C ₂ H ₅ OH	3.3vol%
9	Propylene	C ₃ H ₆	2.0vol%
10	Acetone	C ₃ H ₆ O	2.15vol%
11	Propane	C ₃ H ₈	2.0vol%
12	Butadiene	C ₄ H ₆	1.1vol%
13	Cyclopentane	C ₅ H ₁₀	1.4vol%
14	Benzene	C ₆ H ₆	1.2vol%
15	n-Hexane	n-C ₆ H ₁₄	1.2vol%
16	Toluene	C ₇ H ₈	1.2vol%
17	Heptane	n-C ₇ H ₁₆	1.1vol%
18	Xylene	C ₈ H ₁₀	1.0vol%
19	Ethyl acetate	EtAc	2.1vol%
20	IPA	IPA	2.0vol%
21	MEK	MEK	1.8vol%
22	Methyl methacrylate	MMA	1.7vol%
23	Dimethylether	DME	3.0vol%
24	Methyl isobutyl ketone	MIBK	1.2vol%
25	Tetrahydrofuran	THF	2.0vol%

Note 1) Alarm accuracy, response time etc. are confirmed with calibration gas.

Note 2) Contact Riken Keiki if GP-1000 is required to be calibrated with other than CH₄, i-C₄H₁₀, H₂.

Note 3) Gas selection is not available when GP-1000 is calibrated with other than CH₄, i-C₄H₁₀.

Note 4) The measuring results of the gas selection are intended for guidance only.
For the most accurate measurements, GP-1000 should be calibrated using the target gas.

Outer dimension

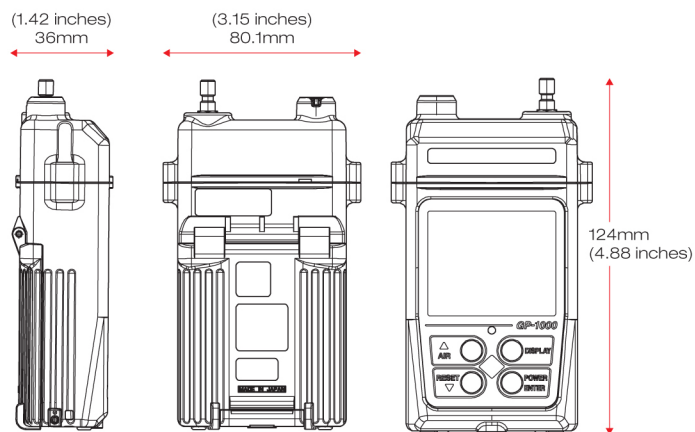

RIKEN KEIKI Co.,Ltd.

2-7-6 Azusawa, Itabashi-ku, Tokyo 174-8744, Japan

Phone : +81-3-3966-1113

Telefax : +81-3-3558-9110

E-mail : intdept@rikenkeiki.co.jp

Web site : <http://www.rikenkeiki.co.jp>

★ Distributed by:



CÔNG TY TNHH MTV MÁY ĐO KHÍ VIỆT NAM

79 Lý Chính Thắng, phường 8, quận 3, Tp.HCM

Tel : (08). 35262987

Fax : (08). 35262980

Email : info@vina-gasdetector.vn

Web : www.vina-gasdetector.vn